



EVALUATING CRACKING DATA QUALITY USING FIELD- LABELED CRACK MAP GROUND REFERENCE

HAOLIN WANG (PRESENTING), PH.D. STUDENT, ZHONGYU YANG, PH.D., RESEARCH ENGINEER II,
YI-CHANG (JAMES) TSAI, PH.D., PROFESSOR

SCHOOL OF CIVIL AND ENVIRONMENTAL ENGINEERING, GEORGIA INSTITUTE OF TECHNOLOGY,
ATLANTA, GEORGIA

JEANNINE MORIARTY (PRESENTING), TRANSPORTATION ENGINEER III

PAVEMENT MANAGEMENT UNIT, CONNECTICUT DEPARTMENT OF TRANSPORTATION



HONORING THE PAST PAVING THE FUTURE

2026 RPUG CONFERENCE • PITTSBURGH, PA • APRIL 28 - MAY 1

OUTLINE

- NEEDS FOR CRACKING DATA QUALITY ASSESSMENT
 - LACK OF CRACK-SPECIFIC DATA QUALITY ASSESSMENT
 - CONNECTICUT DEPARTMENT OF TRANSPORTATION PRACTICE
- PROPOSED GROUND REFERENCE PROCEDURES
- PROPOSED COMPARISON METHOD FOR ASSESSMENT



What Are We Lacking? – Cracking Data Quality Assessment

A lack of effective and practical approaches remains for agencies to assess crack-specific data quality.

Existing methods for **sensor** and **pavement image quality** assessment:

- Sensor certification (hardware-focused)
TPP Standard (PP 106-111)
- Pavement image quality assessment
NCHRP 1106 / PP 119
- Vendor own calibration
Manufacturer Calibration

Lacking:

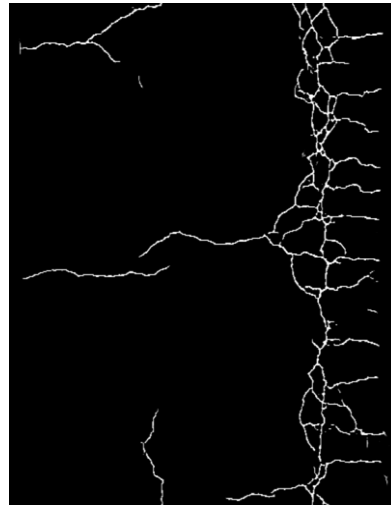

Detected Crack Map

Reflect Real Crack Condition

?



Real-world Crack (Ground Reference)

- 1) How to obtain **ground reference**.
- 2) How to assess quality (**quantify missing crack**).
- 3) **Diagnostic and reasoning for any missing crack**.

CTDOT Practices in 2025- Manual Validation

Testing vs Manual Results



Front image of manual distress

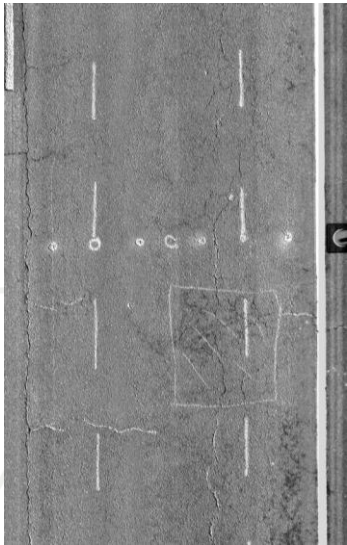

Downward pavement image of manual distress

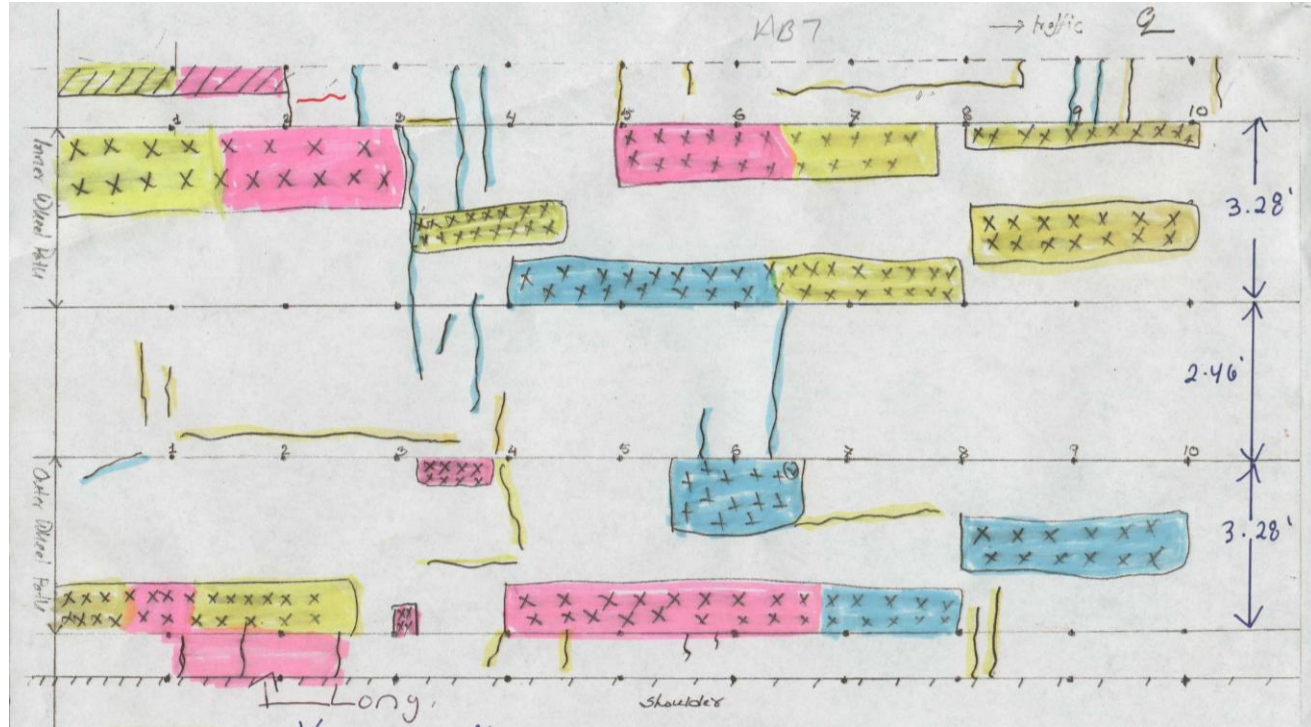

Yellow represents section identified both in **testing** and **manually**
Pink represents picked in **testing** but categorized as **Longitudinal crack** instead of **Alligator**
Blue missed by **testing** but picked up **manually**

Pavement Cracking Data Quality Assessment

Deliverable-focused: *Is the cracking data as delivered good enough for the intended use?*

Proposed Ground Reference Method

Field labeled crack map on pavement surface (draw using paint).

**Any
difference?**

Traditional Ground Reference Method

Crack survey using engineering sheets.

Assessments

1. Visual crack map comparison
2. HPMS % comparison
3. Pixel-level quantification (EHD, missed crack, spurious crack)



Proposed Field Labeled Crack Map

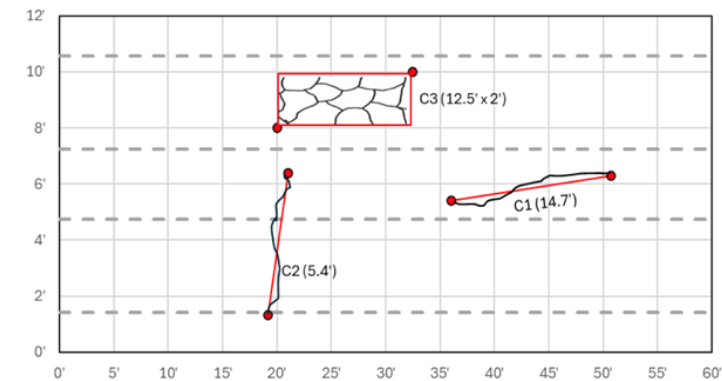
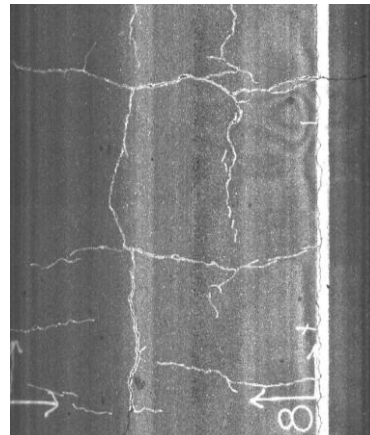

Traditional Crack Survey on Engineering Sheet

Preparation for Ground Reference Procedure

- **Test site selection:**
 1. Cover **single surface type** (asphalt pavement, JPCP, or CRCP)
 2. **50-ft (15-m) sections** for cracking painting practicality (section length justifiable for JPCP to include complete slabs)
 3. **Crack condition** shall be representative, but severity shall be suitable for labeling ease
 4. **Mark selected section** for identification ease
- **Traffic control:** ensure safety
- **Resource allocation**
 1. Test 3D system for data collection + smartphone/drone for supportive data collection
 2. Manual survey-related equipment (e.g., engineering sheets, pens, and measuring wheels)
 3. **Field-labeling-related equipment** (e.g., washable paint, brushes)

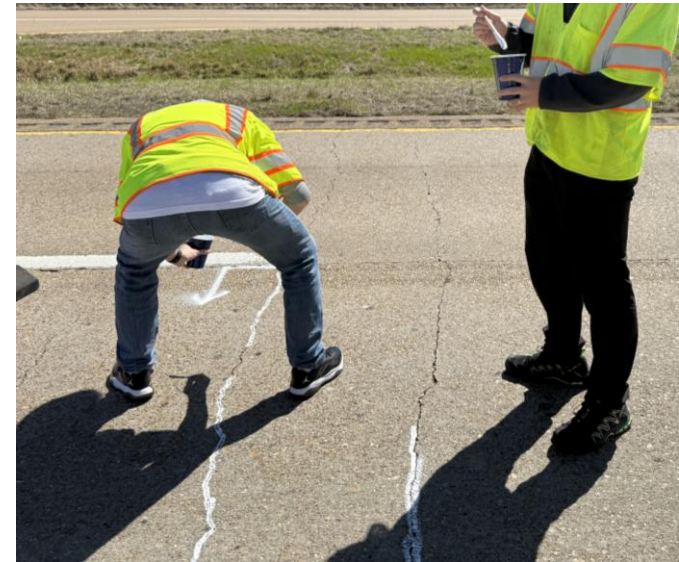

Ground Reference Procedure

Preparation

- **Resource** allocation
- **Test site** selection and marking for visualization
- **Traffic control**

Step 1

Crack survey on engineering sheets

Avoid impact of painted cracks on the survey judgment

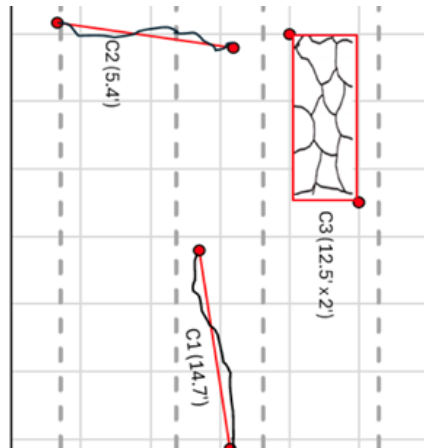

Step 2

Test system scan for **test crack map**

Avoid impact of painted cracks on crack attributes

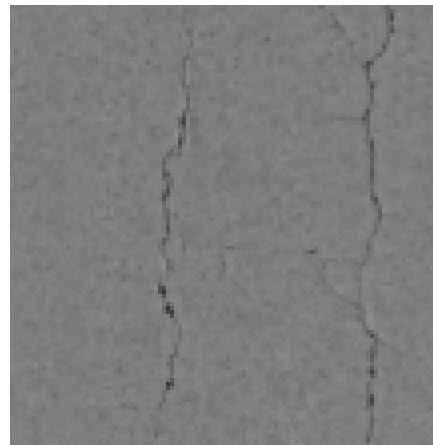

Step 3

Paint on the pavement surface for the **field-labeled crack map** as the ground reference



Step 4

Pavement scan for **digitizing filed-labeled crack map**

Photos from smartphone/ drone can serve as the supporting resource

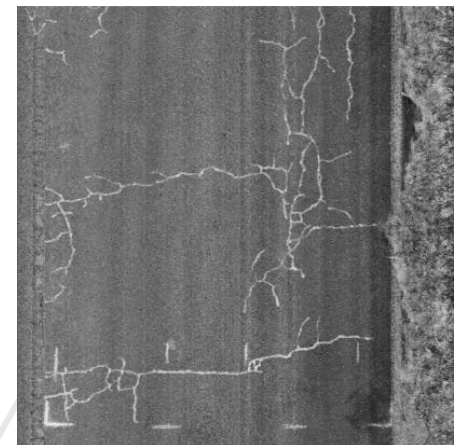

Case Study

Asphalt pavement

Crack detection is done using the test system manufacturer's proprietary algorithm

Test system specs:

1 mm driving directional scanning interval.

1 mm transverse resolution.

0.25 mm vertical accuracy.

4 mm output resolution for intensity and depth images.

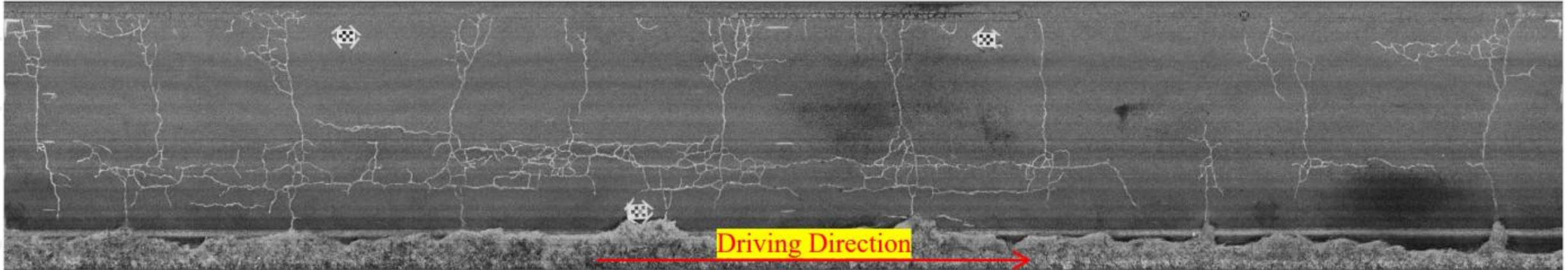

Intensity Image of Case Study Section (After Field Label)

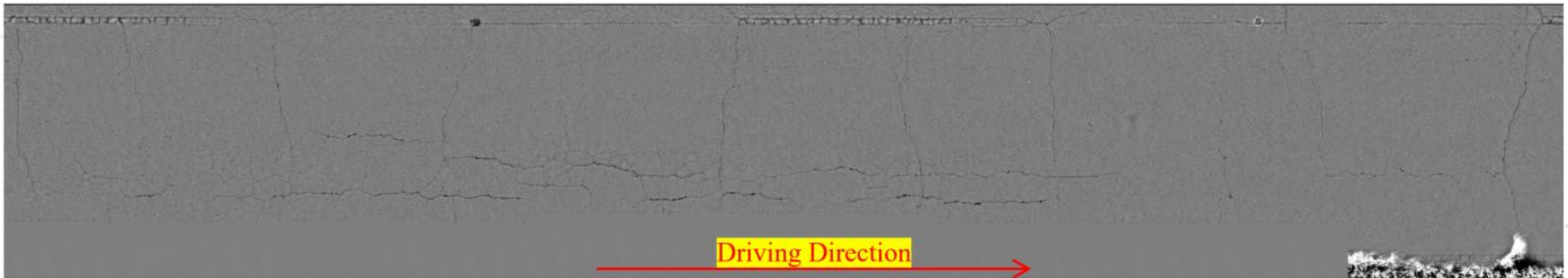

Depth (Range) Image of Case Study Section

Visual Crack Map Comparison

 Alligator cracks in manual survey

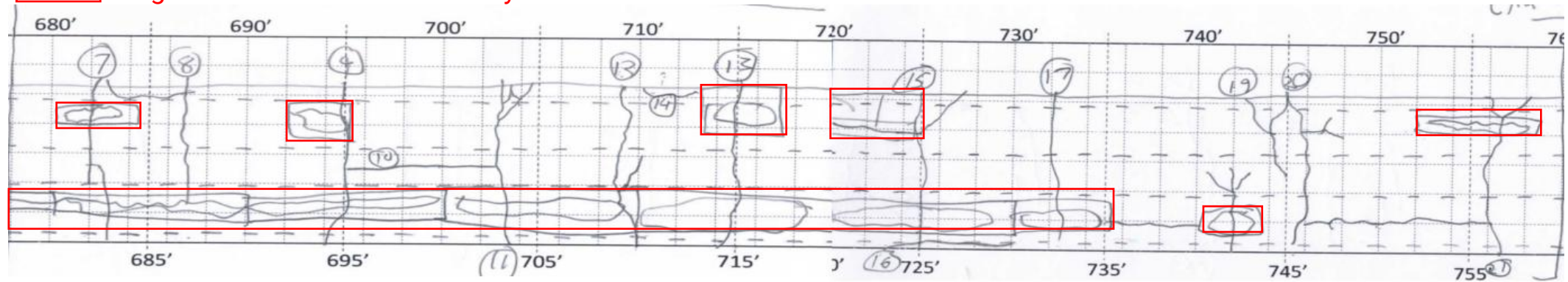

Traditional
Survey Sheet

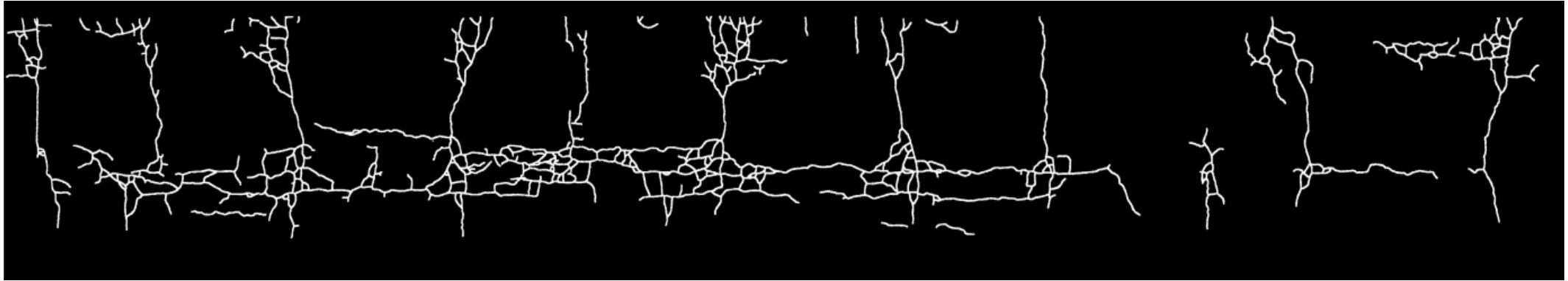

Proposed
Field Labeled
Crack Map



Testing
Crack Map

HPMS Cracking Percentage Reporting Using Crack Maps

HPMS Definition for Asphalt Pavements:

Cracking Percent is the percentage of the total area exhibiting visible fatigue-type cracking (*alligator cracks* + *longitudinal cracks*) for all severity levels in the wheelpath in each section.

HPMS Cracking Percentage for crack maps:

$$W_{Z2} * L_{Z2} + W_{Z4} * L_{Z4}$$

A

- **W** = zone width (zones 2&4 are wheelpath)
- **L** = total length of the affected wheelpath area by *alligator cracks* + *longitudinal cracks*
- **A** = area of whole lane (calculated using 12 ft width * crack map height)

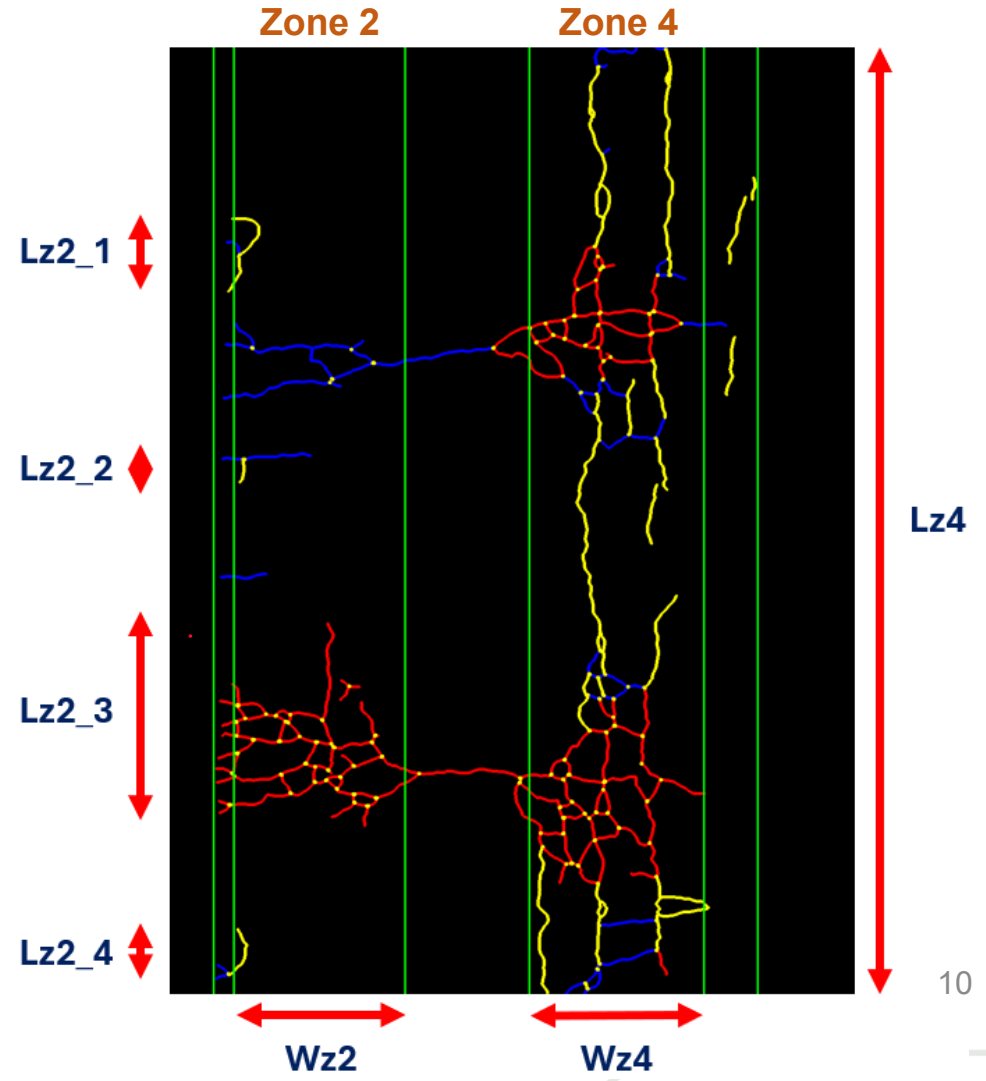

HPMS Reporting Comparison

 Alligator cracks in manual survey

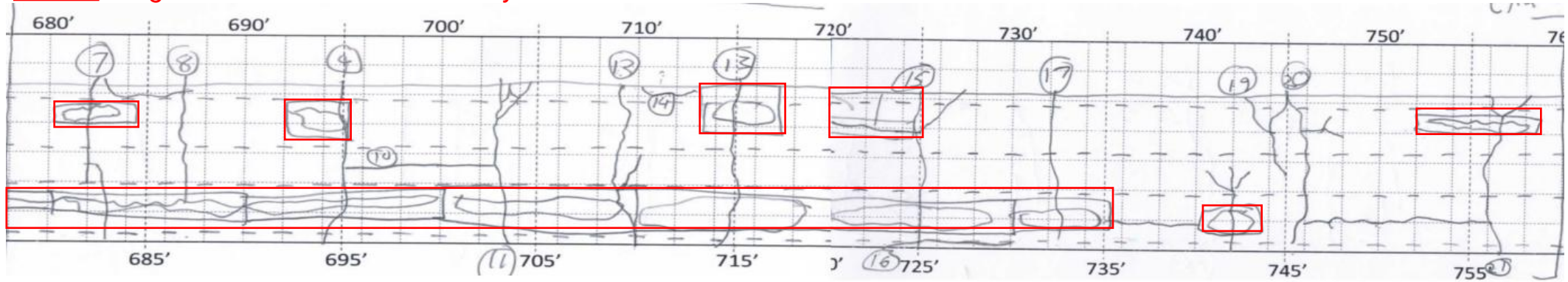

**Traditional
Survey Sheet**
HPMS 38%

**Proposed
Field Labeled
Crack Map**
HPMS 34%

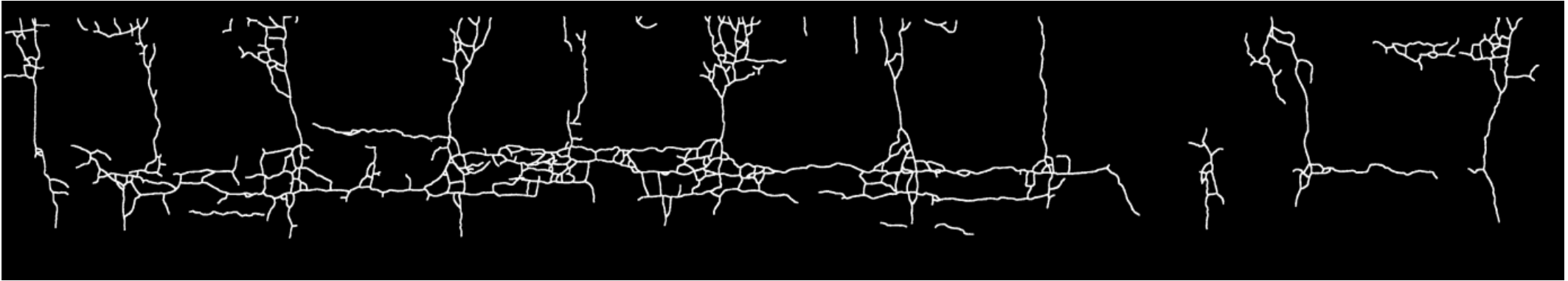

**Test
Crack Map**

HPMS 17%

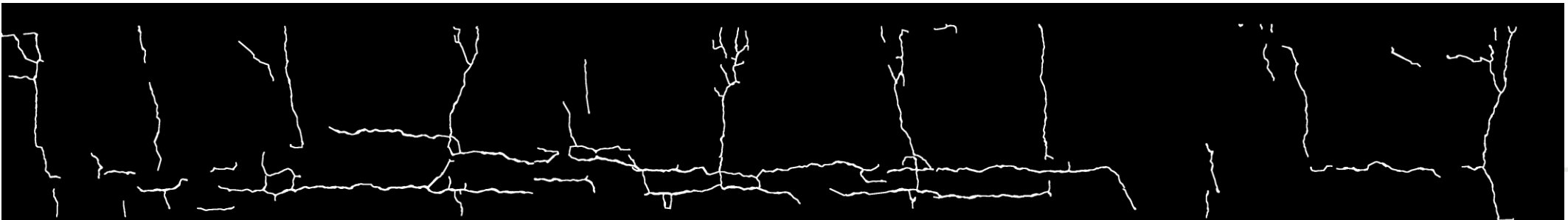

Alligator cracks are largely missed in the testing crack map -> significantly lower HPMS reporting

Pixel-level Comparison Using Field-Labeled Crack Map

- **EHD: 45.29 (0-100 with 100 best crack map quality)**
 - **Medium poor performance.**
- **Missed detection: ~48%**
 - Missed majorly short, thin cracks, leading to the omission of dense, interconnected crack networks, with only major longitudinal and transverse cracks left.
- **Spurious detection: ~5%**
 - The testing system had limited spurious detection.



Wet surface + coarse surface (chip seal) may be the reason for missed detection.

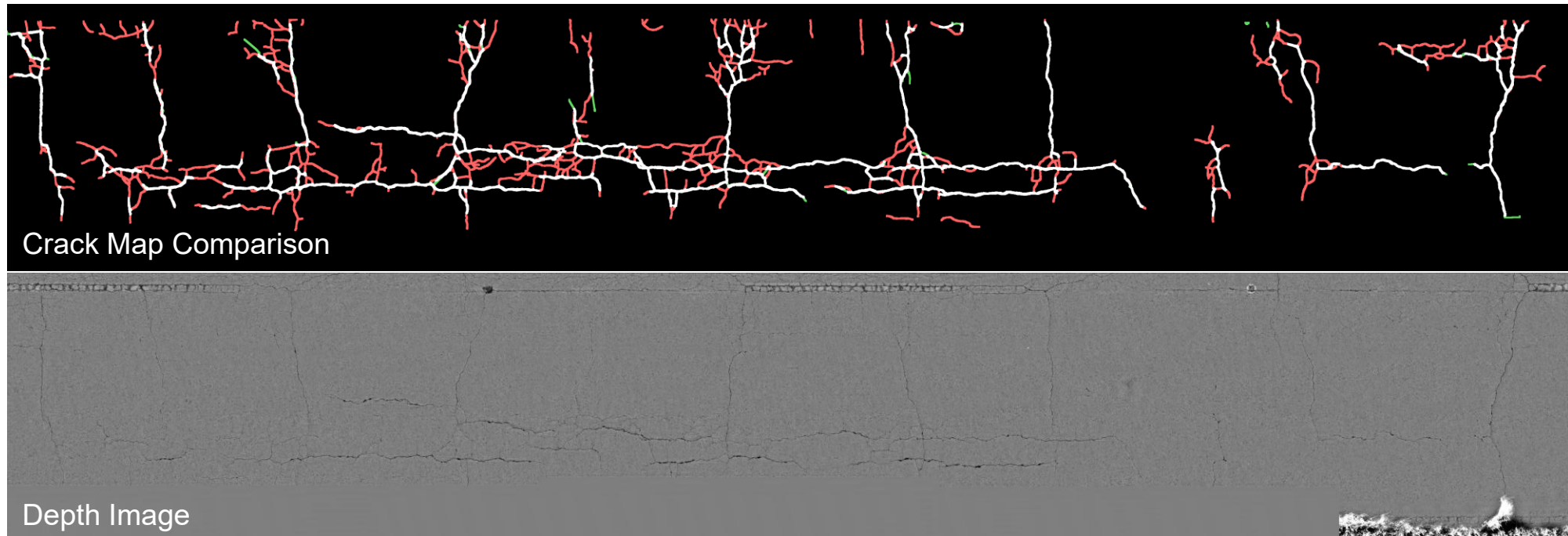

Red: Missed detection
Green: Spurious detection
White: Correct detection

A Closer Look on Crack Map Issue

- **Missed detection**
Omitted dense, interconnected crack networks, with only major longitudinal and transverse cracks left
- **Spurious detection**
Algorithm performance variance

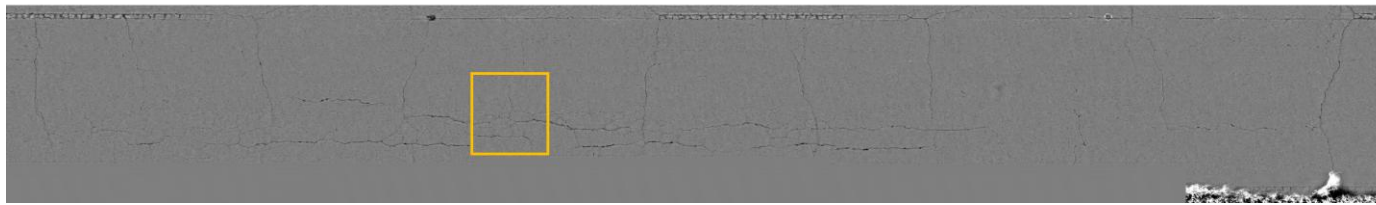
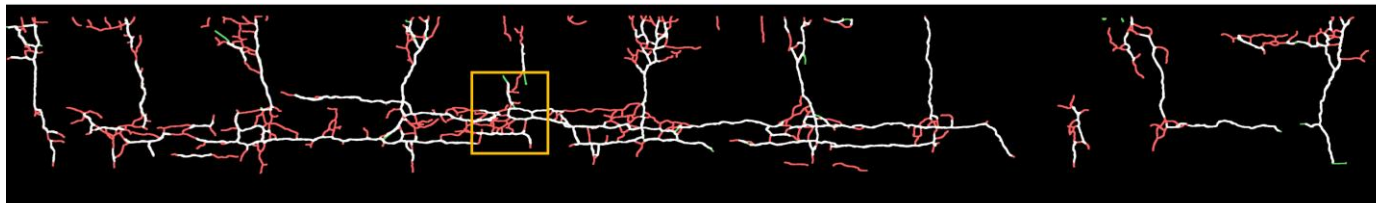
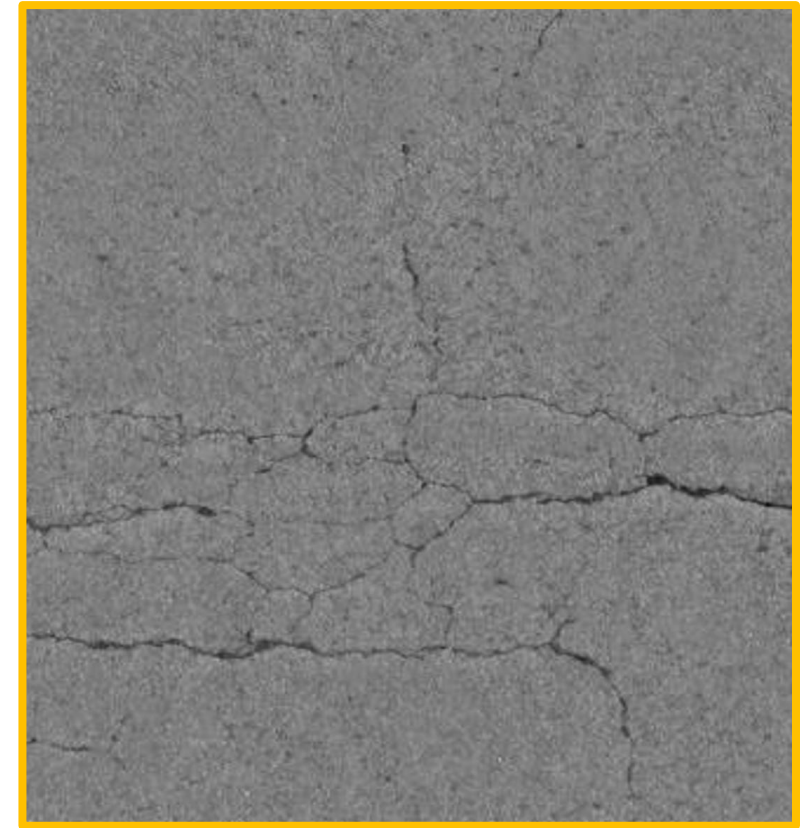

One Step Further: Diagnosing Missing Cracks

Identify sensor issues (e.g., pavement image quality) or crack-detection issues that result in missing cracks.

- **Sensor issue**– Using reference objects with designed geometry to evaluate the sensor quality.
- **Crack detection issue**– Crack annotation on pavement images to evaluate crack detection algorithms.

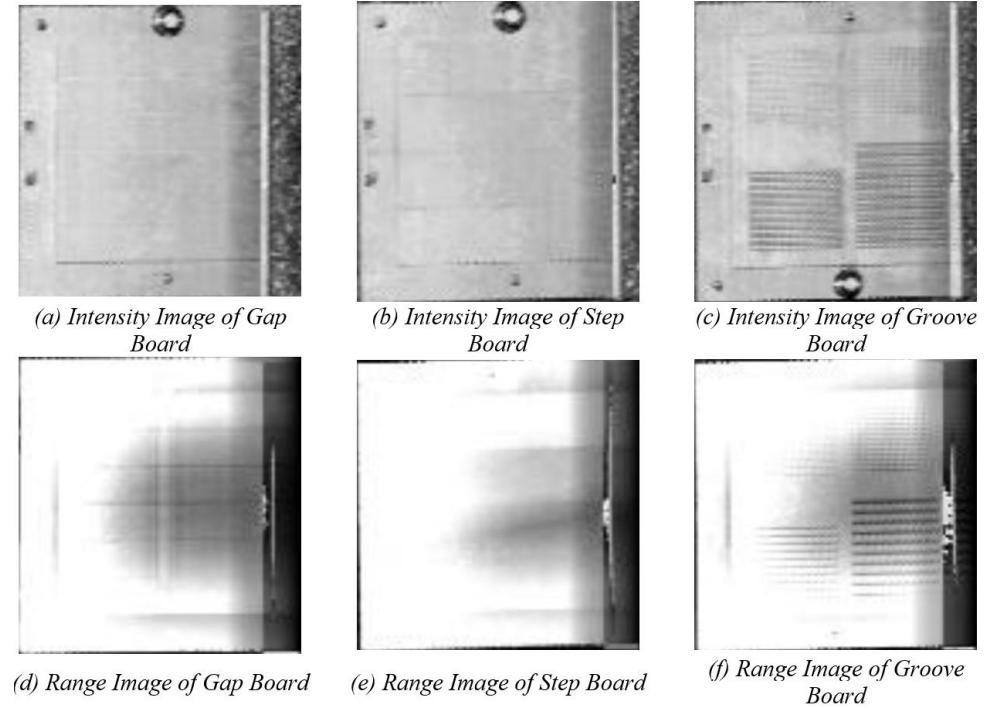

Ground Reference Objects Scanning

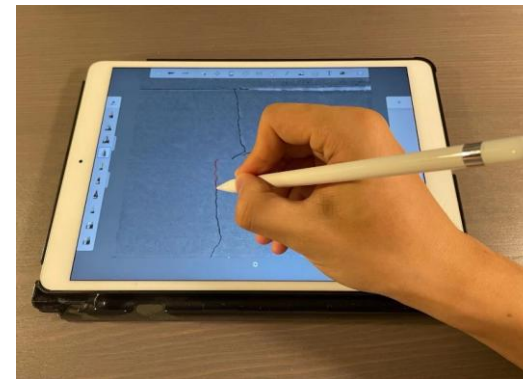

Crack Manual Annotation

CTDOT Practices in 2026-Data Collected



Field Labeled Crack Map

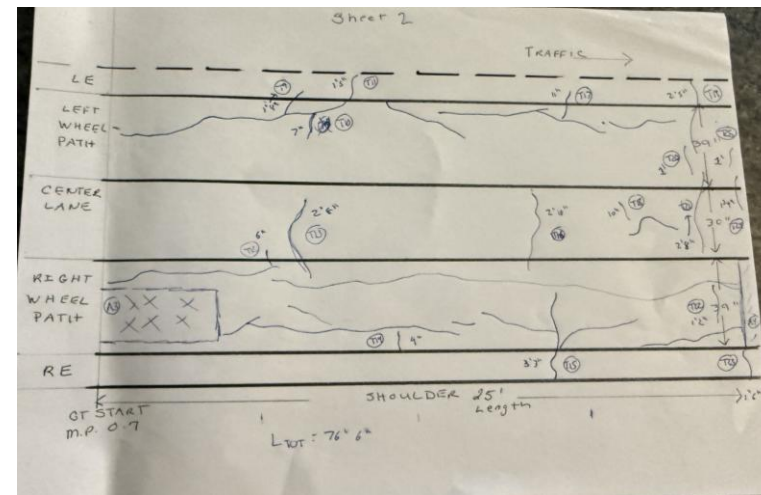
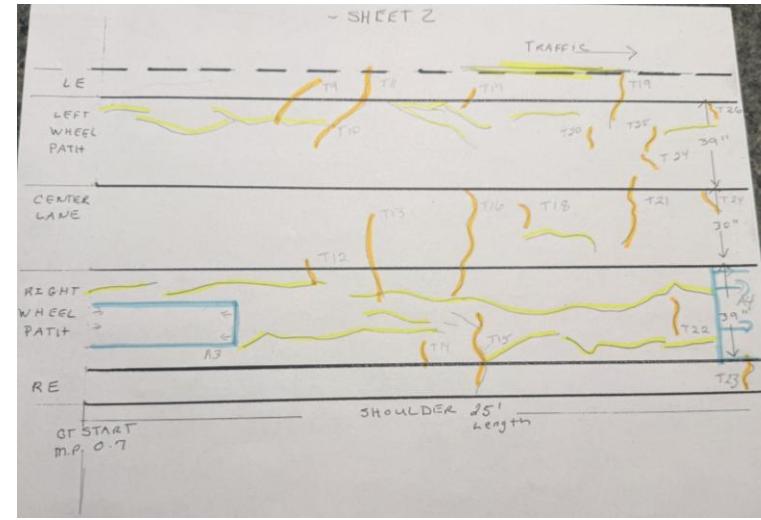

Manual Sheet Crack Map

Conclusions

Crack-specific Data Quality Assessment Methods

1. Proposed executable **ground reference** procedures: **field-labeled crack map**
 - Test site selection, equipment, and material
 - Step-by-step procedure for field labeling and ground reference crack map generation
2. Proposed **assessment methods** to evaluate crack map quality
 - Visual assessment for straightforward comparison
 - HPMS reporting assessment for comparison in routine practice
 - Pixel-level assessment for quantitative comparison
3. Introduced useful methods to **diagnose sensor vs. detection algorithm issues** that lead to missing cracks

Recommendations

1. Establish Routine Test

Prepare routine test sites for ground reference and test data collection, covering different pavement types for broader applicability validation

2. Multi-System Testing

Conduct cross-system comparisons of different collection systems

3. Acceptance Determination

Determine the acceptance of the cracking data quality with per agencies' own needs

4. Incorporating into Agencies' Data Quality Management Plan

Recommend the work with the vendor (or using the in-house system) on the state's own situation regarding the crack type classification, providing more state-specific information

ACKNOWLEDGMENTS-Funding Support

The research is part of the ***NCHRP project 01-57B Validating Proposed Definitions for Comparable Pavement Cracking Data***, which is part of the National Cooperative Highway Research Program (NCHRP). NCHRP is administered by the Transportation Research Board (TRB) and funded by participating member states of the American Association of State Highway and Transportation Officials (AASHTO). NCHRP also receives critical technical support from the Federal Highway Administration (FHWA), United States Department of Transportation.

ACKNOWLEDGMENTS

The authors would like to thank

- Dr. Georgene Geary, Dr. Ryan Salameh, Mr. Doug Frith, Dr. Carlos Cary, and Connecticut Department of Transportation (CTDOT) for their valuable input and discussion.
- Florida Department of Transportation (FDOT), the Mississippi Department of Transportation (MDOT), the Texas Department of Transportation (TxDOT), and Pavemetrics Systems and Pathway Services for their help and effort in data collection.

THANK YOU!

QUESTIONS?

HAOLIN WANG, ZHONGYU YANG, YI-CHANG (JAMES) TSAI

GEORGIA INSTITUTE OF TECHNOLOGY

JEANNINE MORIARTY

CONNECTICUT DEPARTMENT OF TRANSPORTATION



HONORING THE PAST PAVING THE FUTURE